

3500/25 Enhanced Keyphasor® Module

Bently Nevada* Asset Condition Monitoring

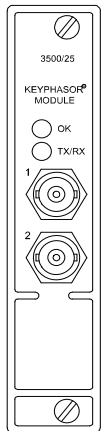

Description

The 3500/25 Enhanced Keyphasor* Module is a half-height, two-channel module used to provide Keyphasor signals to the monitor modules in a 3500 rack. The module receives input signals from proximity probes or magnetic pickups and converts the signals to digital Keyphasor signals that indicate when the Keyphasor mark on the shaft coincides with the Keyphasor transducer. The 3500 Machinery Protection System can accept up to four Keyphasor signals for normal configuration and up to eight Keyphasor signals in a paired configuration.

Note: A Keyphasor signal is a once-per-turn or multiple-event-per-turn pulse from a rotating shaft or gear used to provide a precise timing measurement. This allows 3500 monitor modules and external diagnostic equipment to measure shaft rotative speed and vector parameters such as 1X vibration amplitude and phase.

The Enhanced Keyphasor Module is an improved 3500 system module. It offers expanded Keyphasor signal processing capabilities over the previous design while maintaining complete downward-compatibility in terms of form, fit and function with existing Keyphasor modules for use in legacy systems. The Keyphasor module, PWA 125792-01, is completely replaced by the more recent 149369-01 module.

When a system Keyphasor input is required for Triple Modular Redundant (TMR) applications, the 3500 system should employ two Keyphasor modules. In this configuration the modules work in parallel to provide both a primary and secondary Keyphasor signal to the other modules in the rack.

A system with more than four Keyphasor inputs may use a paired configuration provided that there are no more than four primary Keyphasor input signals. A paired configuration requires two consecutive monitoring positions in either the upper/lower or both half-slot positions. Four Keyphasor modules will accept four primary and four backup input channels and provide four output channels (one per module). A configuration of two paired and one non-paired (three Keyphasor modules total) is also possible. In such a configuration, the user may configure the one non-paired Keyphasor (order either two 2-channel or one 1-channel and one 2-channel option)

The Isolated Keyphasor I/O module is designed for applications in which the Keyphasor signals are tied in parallel to multiple devices and require isolation from other systems, such as a control system. The Isolated I/O module was created specifically for Magnetic Pickup applications but is compatible with and will provide isolation for Proximito* applications as long as an external power supply is provided. Note that the intent of this I/O module was primarily to measure shaft speed and not phase. The module can provide phase measurements, but this I/O introduces a slightly higher phase shift than the Non-Isolated I/O version. Figure 1 shows the amount of phase shift that the Isolated I/O modules will add at different machine speeds.

Enhanced product features include generation of once-per-turn event signals from multi-event-per-turn inputs, field-upgradeable firmware, and asset management data reporting.



Specifications and Ordering Information
Part Number 141532-01
Rev. H (01/10)



Specifications

Inputs

Power Consumption

3.2 Watts typical.

Signal

Each Keyphasor Module accepts up to two transducer signals from proximity probe transducers or magnetic pickups. The input signal range is +0.8 V to -21.0 V (Non-Isolated I/O modules) or +5V to -11V (Isolated I/O modules). Signals exceeding this range are limited internally by the module. Passive magnetic pickups require a shaft rotative speed greater than 200 rpm (3.3 Hz).

Input Impedance

21.8 k Ω minimum.

Signal Conditioning

Speed/ Frequency Signal Ranges

Input range of 1 to 1,200,000 cpm (0.017 to 20 kHz). Supports multiple events per revolution to a maximum of 20 kHz.

Output range of 1 to 99,999 cpm (0.017 to 1667 Hz)

Speed/ Frequency Signal Accuracy

Specified at +25 °C (+77 °F).

Non-processed Signals

- 0.017 to 100 Hz ... ± 1 cpm
- 101 to 500 Hz ... ± 8 cpm
- 501 to 20 kHz ... $\pm 1\%$ of cpm

Processed Signals

- 0.017 to 60 Hz ... ± 1 cpm
- 61 to 150 Hz ... ± 8 cpm
- 151 to 20 kHz ... $\pm 1\%$ of cpm

Transducer Conditioning

Auto Threshold

Minimum signal amplitude for triggering is 2 volts peak to peak and minimum frequency is 120 rpm (2 Hz).

Manual Threshold

Use for any input above 0.017 Hz (1 rpm for 1 event/revolution). User-selectable from 0 to -20 volts dc. Minimum signal amplitude for triggering is 500 millivolts peak to peak.

Hysteresis

User-selectable from 0.2 to 2.5 Volts.

Outputs

Buffered Keyphasor Signals

Two buffered Keyphasor outputs are available at the front of the rack via coaxial connectors. Two buffered Keyphasor outputs are also available at the back of the rack via Euro Style connectors.

Output Impedance

504 Ω maximum buffered output impedance.

Keyphasor Transducer Power Supply

-24 Vdc, 40 mA maximum per channel.

Front Panel LEDs

OK LED

Indicates when a fault has been detected in the Keyphasor Module.

TX/RX LED

Indicates when the Keyphasor Module is communicating with the Rack Interface Module (RIM).

Environmental Limits

Operating Temperature

-30 °C to +65 °C (-22 °F to +150 °F) when used with Keyphasor I/O Module other than the Internal Barrier version.

0 °C to +65 °C (32 °F to +150 °F) when used with Keyphasor Internal Barrier I/O Module (Internal Termination).

Storage Temperature

-40 °C to +85 °C (-40 °F to +185 °F).

Humidity

95%, non-condensing.

Compliance and Certifications

EMC

Standards:

EN 61000-6-2 Immunity for Industrial Environments

EN 55011/CISPR 11 ISM Equipment

EN 61000-6-4 Emissions for Industrial Environments

European Community Directives:

EMC Directive 2004/108/EC

Electrical Safety

Standards:

EN 61010-1

European Community Directives:

2006/95/EC Low Voltage

For further certification and approvals information please visit the following website:

http://www.ge-energy.com/prod_serv/products/oc/en/bently_nevada.htm

Hazardous Area Approvals

North American

Approval Option (01)

Class I, Div 2

Groups A, B, C, D

T4 @ Ta = -20 °C to +65 °C

(-4 °F to +150 °F)

North American

Approval Option (02)

When used with I/O module ordering options without internal barriers:

A/Ex nC[L] IIC

Class I, Zone 2

Class I, Div 2, Groups A,B,C,D

T4 @ Ta = -20 °C to +65 °C

(-4 °F to +150 °F)

When used with I/O module ordering options with internal barriers:

A/Ex nC[ia] IIC

Class I, Zone 2/(0)

Class I, Div I, Groups A,B,C,D

T4 @ Ta = -20 °C to +65 °C

(-4 °F to +150 °F)

ATEX

Approval Option (02)

For Selected Ordering Options
with ATEX/CSA agency
approvals:

 II 3/(3) G

EEx nCAL[L] IIC

T4 @ Ta = -20°C to +65°C

(-4°F to +150°F)

Brazil

Approval Option (02)

For Selected Ordering Options
with ATEX/North American
agency approvals:

Br-Ex nCAL [ia] IIC T4

Br-Ex nCAL [nL] IIC T4

T4 @ Ta = -20 °C to +65 °C

(-4 °F to +150 °F)

Note: When used with Internal Barrier I/O
Module, refer to specification sheet
141495-01 for approvals information.

For further certification and approvals information please visit the
following website:

http://www.ge-energy.com/prod_serv/products/oc/en/bently_nevada.htm

Physical

Main Module

Dimensions

Height x Width x Depth)

119.9 mm x 24.4 mm x 256.5 mm

(4.72 in x 0.96 in x 10.10 in).

Weight

0.34 kg (0.76 lbs.).

I/O Module

Dimensions

(Height x Width x Depth)

241.3 mm x 24.4 mm x 103.1 mm

(9.50 in x 0.96 in x 4.06 in).

Weight

0.46 kg (1.01 lbs.).

Rack Space Requirement

Main Module

1 half-height front slot.

The half-height main modules
require a special mounting
adapter for mounting in the full-
height slots. The user can place
the main modules in any one of
the 14 available slots. Each rack
may have no more than two main
modules, one in a top half-slot
and one in a bottom half-slot.

I/O Modules

1 full-height rear slot.

Ordering Considerations

General

External Termination Blocks
cannot be used with Internal
Termination I/O modules.

When ordering I/O Modules with
External Terminations, the
External Termination Blocks and
Cables must be ordered
separately.

*There are a number of technical
considerations involved in using
the expanded signal processing
functions of the Enhanced
Keyphasor Module. A qualified
Bently Nevada sales
representative should be
consulted prior to specifying or
ordering modules for such
applications.*

Internal Barrier I/O Module

Consult the 3500 Internal Barrier
specification sheet (part number
141495-01) if the Internal Barrier
Option is selected.

Product Description**Enhanced Keyphasor Module****3500/25-AXX-BXX-CXX****A:** Number of channels

- 0 1** Single half-height 2-channel Keyphasor card (order for 2-channels)
- 0 2** Two half-height 2-channel Keyphasor cards (order for 4-Channels)

B: Type of I/O Module

- 0 1** I/O module with Internal Terminations
- 0 2** I/O module with External Terminations
- 0 3** Internal Barrier I/O with Internal Terminations
- 0 4** Isolated I/O module with Internal Terminations
- 0 5** Isolated I/O module with External Terminations

C: Agency Approval Option

- 0 0** Not required
- 0 1** CSA/NRTL/C (Class 1, Div 2)
- 0 2** ATEX/CSA (Class 1 Zone 2)

Note: Agency Approval Option C 02 is only available with Ordering Options B 01 and B 03.

External Termination Blocks

- 128718-01** Keyphasor External Termination Block (Euro Style Connectors)
- 128726-01** Keyphasor External Termination Block (Terminal Strip Connectors)

Cables**3500 Keyphasor (KPH) Signal to External Termination (ET) Block Cable
129530-AXXX-BXX****A:** Cable Length

- 0 0 0 5** 5 feet (1.5 metres)
- 0 0 0 7** 7 feet (2.1 metres)
- 0 0 1 0** 10 feet (3 metres)
- 0 0 2 5** 25 feet (7.5 metres)
- 0 0 5 0** 50 feet (15 metres)
- 0 1 0 0** 100 feet (30.5 metres)

B: Assembly Instructions

- 0 1** Not assembled
- 0 2** Assembled

Spares**149369-01**

Enhanced Keyphasor Module

Note: This module may be ordered as a direct plug-in replacement for Keyphasor Module 125792-01.

125800-01

Keyphasor I/O Module (Internal Terminations)

126648-01

Keyphasor I/O Module (External Terminations)

125800-02

Isolated Keyphasor I/O Module (Internal Terminations)

126648-02

Isolated Keyphasor I/O Module (External Terminations)

135473-01

Keyphasor I/O Module (Internal Barriers and Internal Terminations.

04425545

Grounding Wrist Strap (single use)

00580438

Connector Header, Internal Termination, 4-Position, Green

00502133

Connector Header, Internal Termination, 12-Position, Blue

129770-01

Keyphasor Module Manual

Half-height Card Adaptor:**125388-01**

Half-height Chassis

125565-01

Card Guide

04300111

Assembly Screws (Order Qty. 3)

Figures and Tables

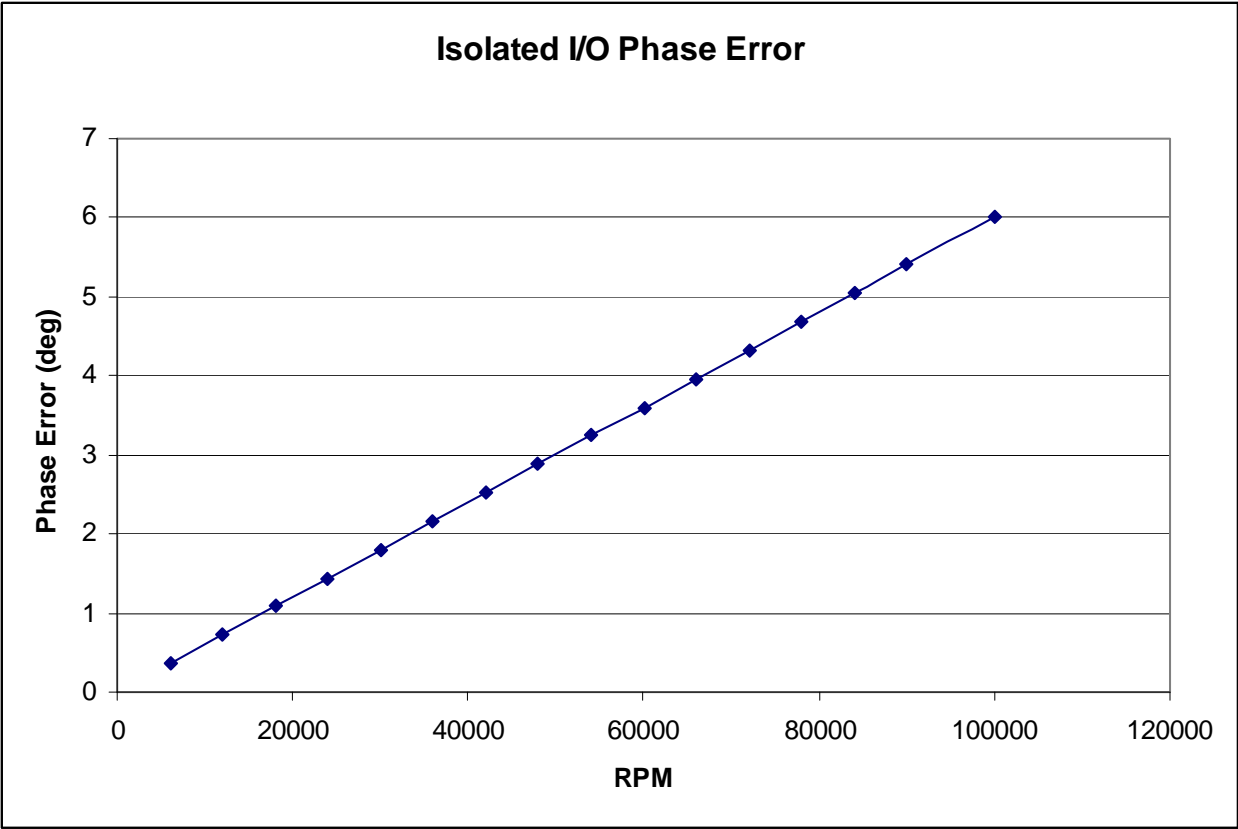

Figure 1

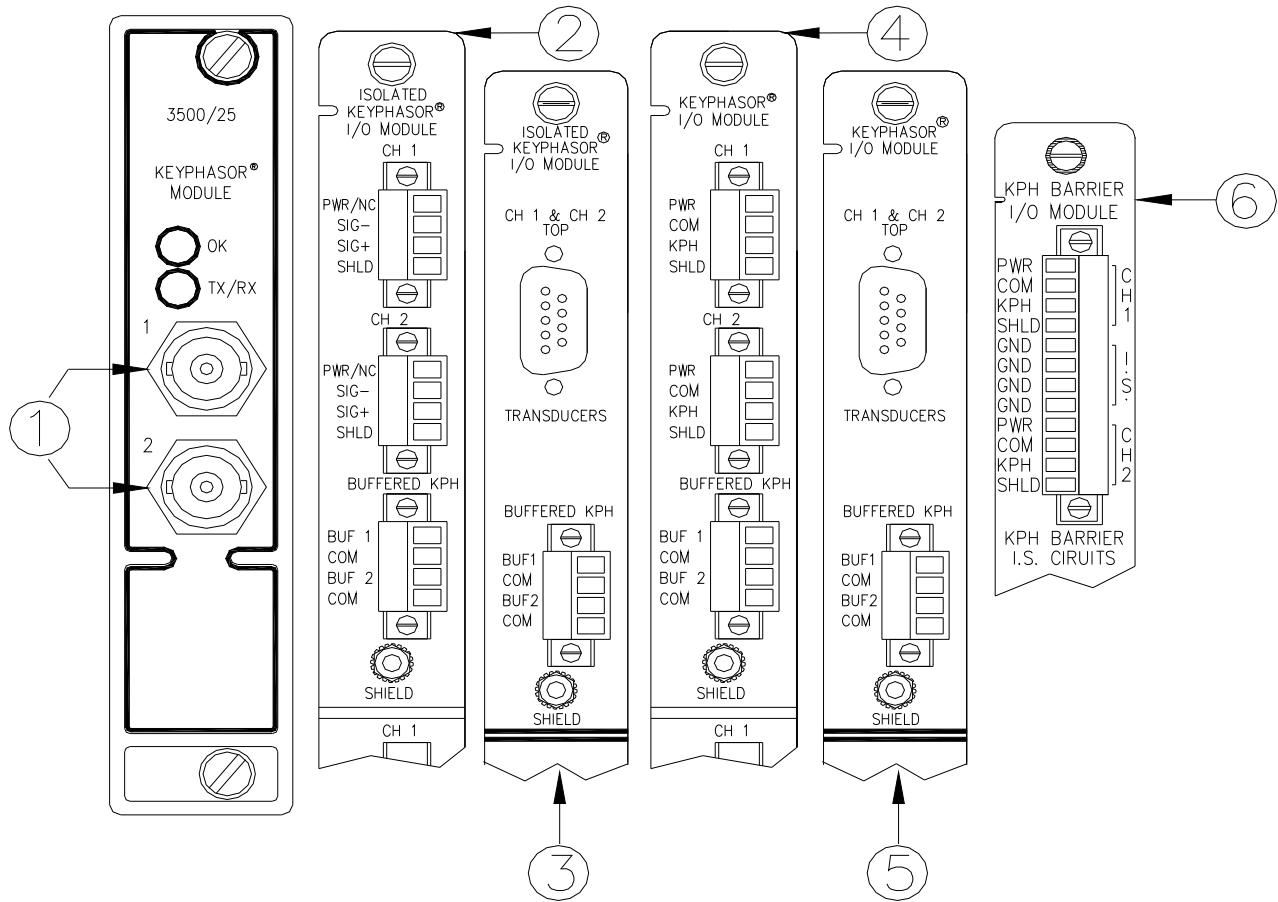

Figure 2: Front and Rear View of Keyphasor® module

- 1) Buffered Transducer Outputs
- 2) I/O Module, Isolated Internal Termination
- 3) I/O Module, Isolated External Termination
- 4) I/O Module, Non-Isolated Internal Termination
- 5) I/O Module, Non-Isolated External Termination
- 6) Barrier I/O Module, Internal Termination

All specifications are subject to change without notice.

* Denotes trademarks of Bently Nevada, Inc., a wholly owned subsidiary of General Electric Company.

© 1999 – 2010 Bently Nevada, Inc. All rights reserved.

1631 Bently Parkway South, Minden, Nevada USA 89423

Phone: 775.782.3611 Fax: 775.215.2873

www.ge-energy.com/bently

Specifications and Ordering Information
Part Number 141532-01
Rev. H (01/10)